

Simple Ising machines for educational and research purposes

Dr. Sven Köppel
koeppel@anabrid.com

Shrish Roy
roy@anabrid.com

2024-04-18
International Workshop on Ising Machines
2024, Messina, Italy

Lucas yesterday 15 minutes on: Delay in self-synchronized networks & 2nd order Kuramoto model.

Sven 15 minutes on: The Analog Paradigm of computation, open hardware for education.

Shrish 15 minutes on: Early results on a small Ising machine we built on this platform.

Simple Ising machines for educational and research purposes

Dr. Sven Köppel
koepfel@anabrid.com

Shrish Roy
roy@anabrid.com

2024-04-18
International Workshop on Ising Machines
2024, Messina, Italy



Founded: 2020

Vision: Analog computing as something third next to digital and quantum.

Mission: Bringing classical analog computing on a microchip.

Classical analog computing: operational-amplifier based, black box model of computing elements



Heathkit Analog Computer H1

www.technikum29.de

www.analogcomputermuseum.org



Founded: 2020

Vision: Analog computing as something third next to digital and quantum.

Mission: Bringing classical analog computing on a microchip.

Producing: Analog Paradigm discrete Computers.

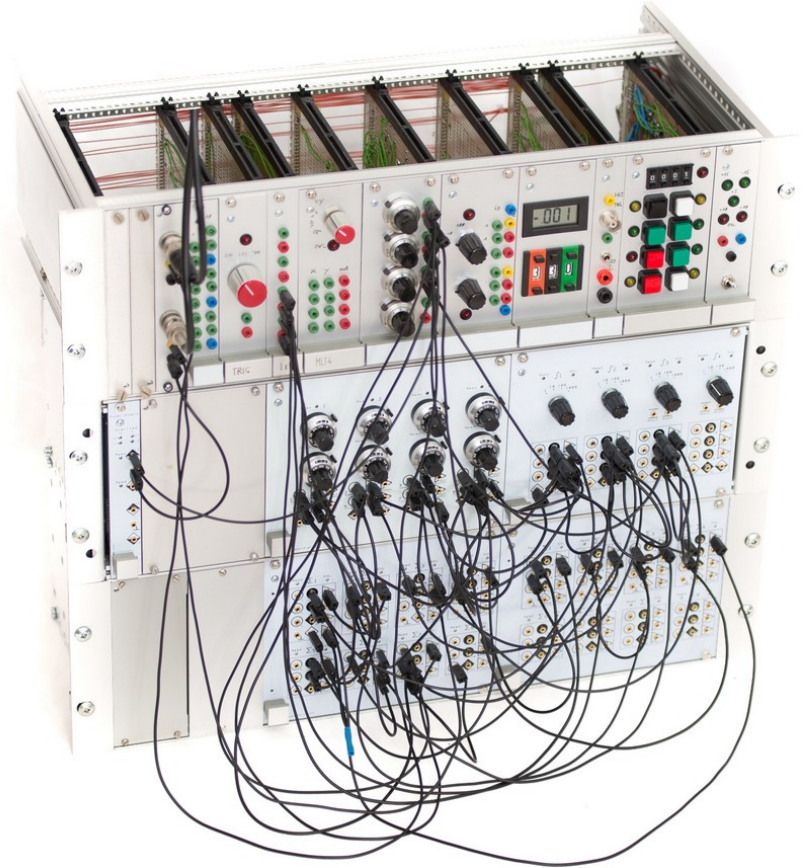

Analog Paradigm Model-1
www.analog-paradigm.com



Founded: 2020

Vision: Analog computing as something third next to digital and quantum.

Mission: Bringing classical analog computing on a microchip.

Producing: Analog Paradigm discrete Computers.

The Analog Thing
www.the-analog-thing.org



What hinders contemporary computer design to proceed?

48 Years of Microprocessor Trend Data

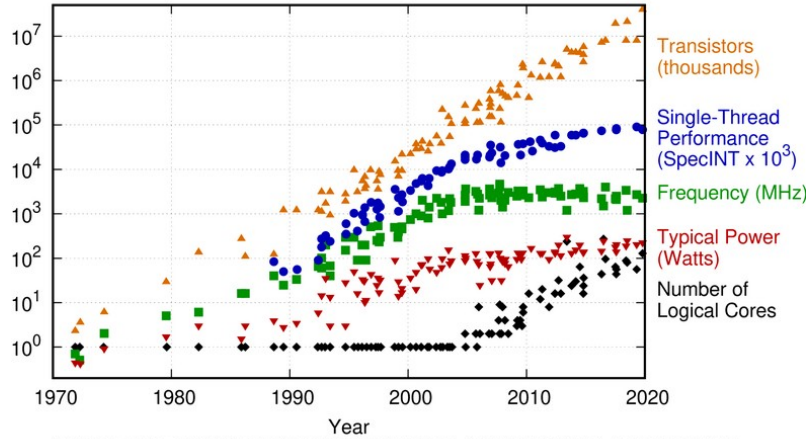

Original data up to the year 2010 collected and plotted by M. Horowitz, F. Labonte, O. Shacham, K. Olukotun, L. Hammond, and C. Batten. New plot and data collected for 2010-2019 by K. Rupp.

Von-Neumann-Bottleneck

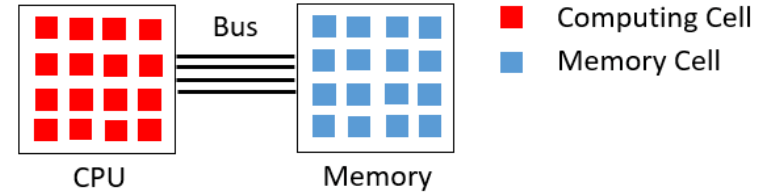

Parallelization has limits

Amdahl's Law

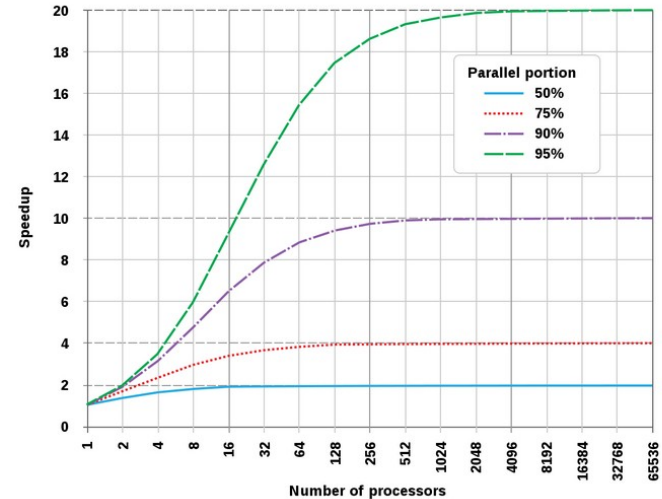

The Energy barrier

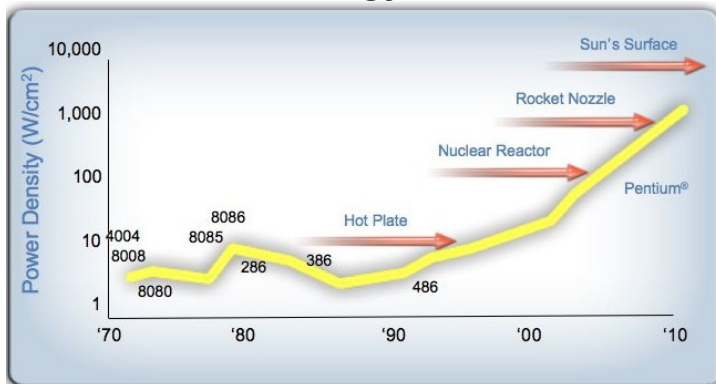

Large scale computing is all about energy

How not to do AI

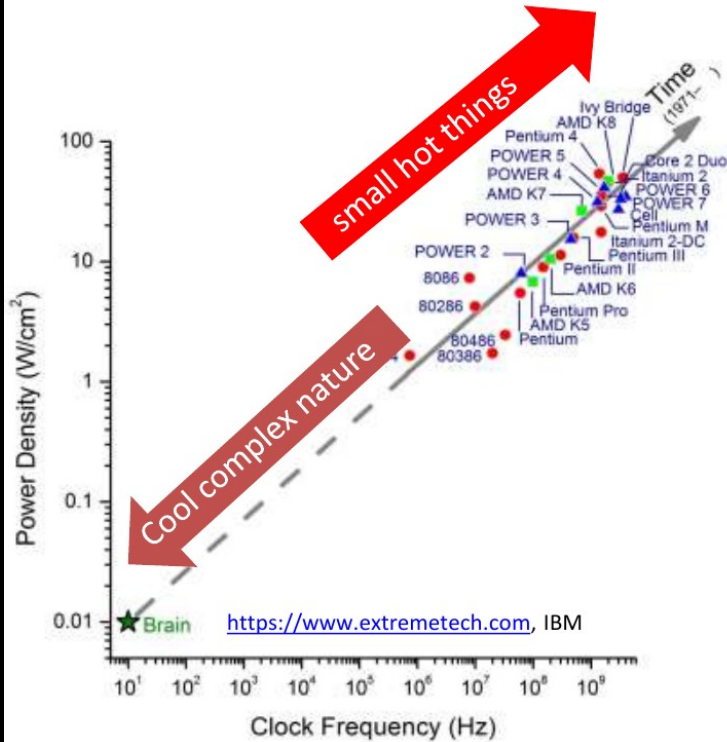

Computing eats the world

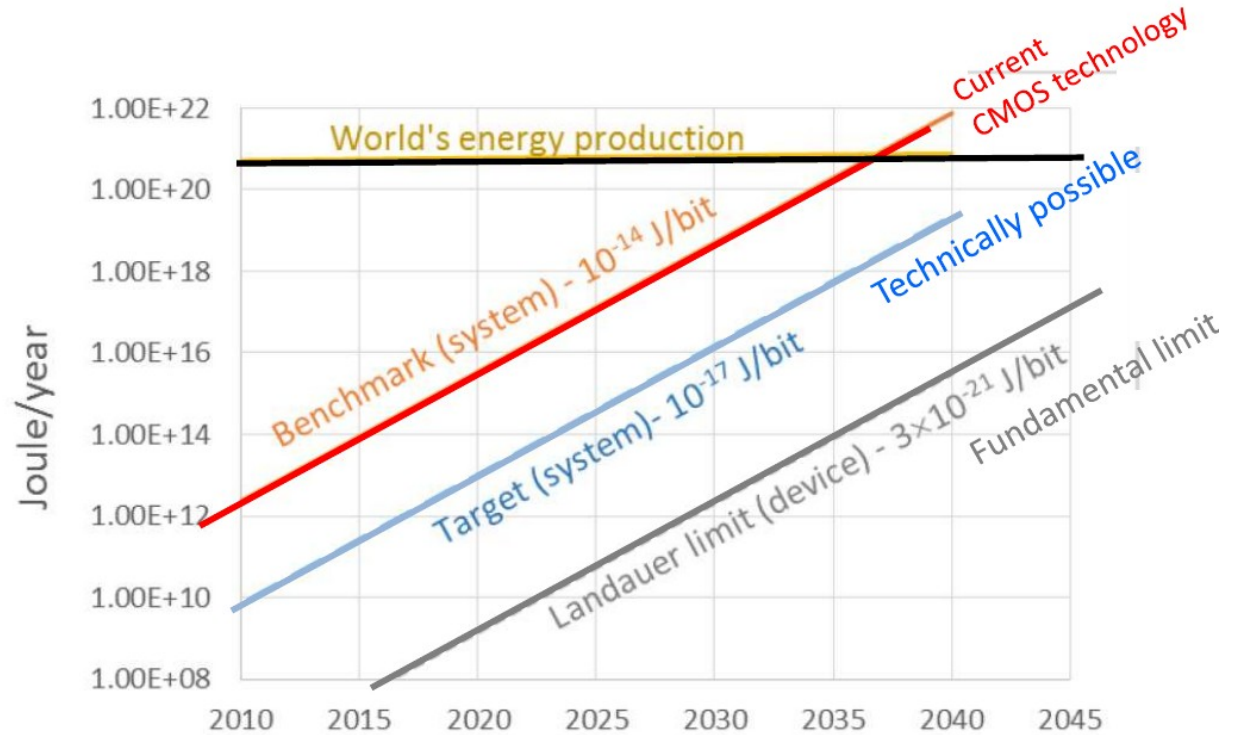

Analogues

Digital Arithmetics

4	7	3	.	1	7
		4	7	3	0
	+	₁ 3	3	1	1
		8	0	4	1

Analog processes in nature

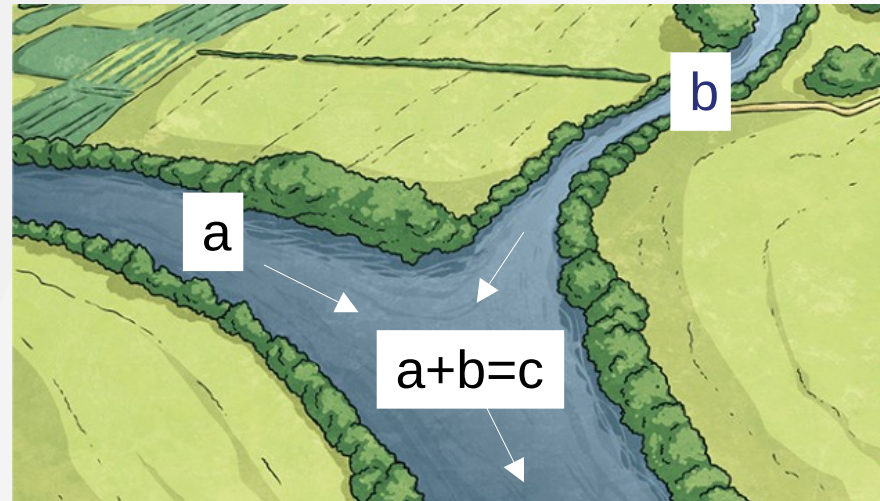

- Uses algorithms
- Inherently clocked and serial
- Based on memory
- Energy barrier, von-Neumann bottleneck
- Happens in real-time
- Continuous and parallel
- Initial state preparation and Measurement-based
- **Resetting Moore's law**



Analog vs digital: Advantages and disadvantages

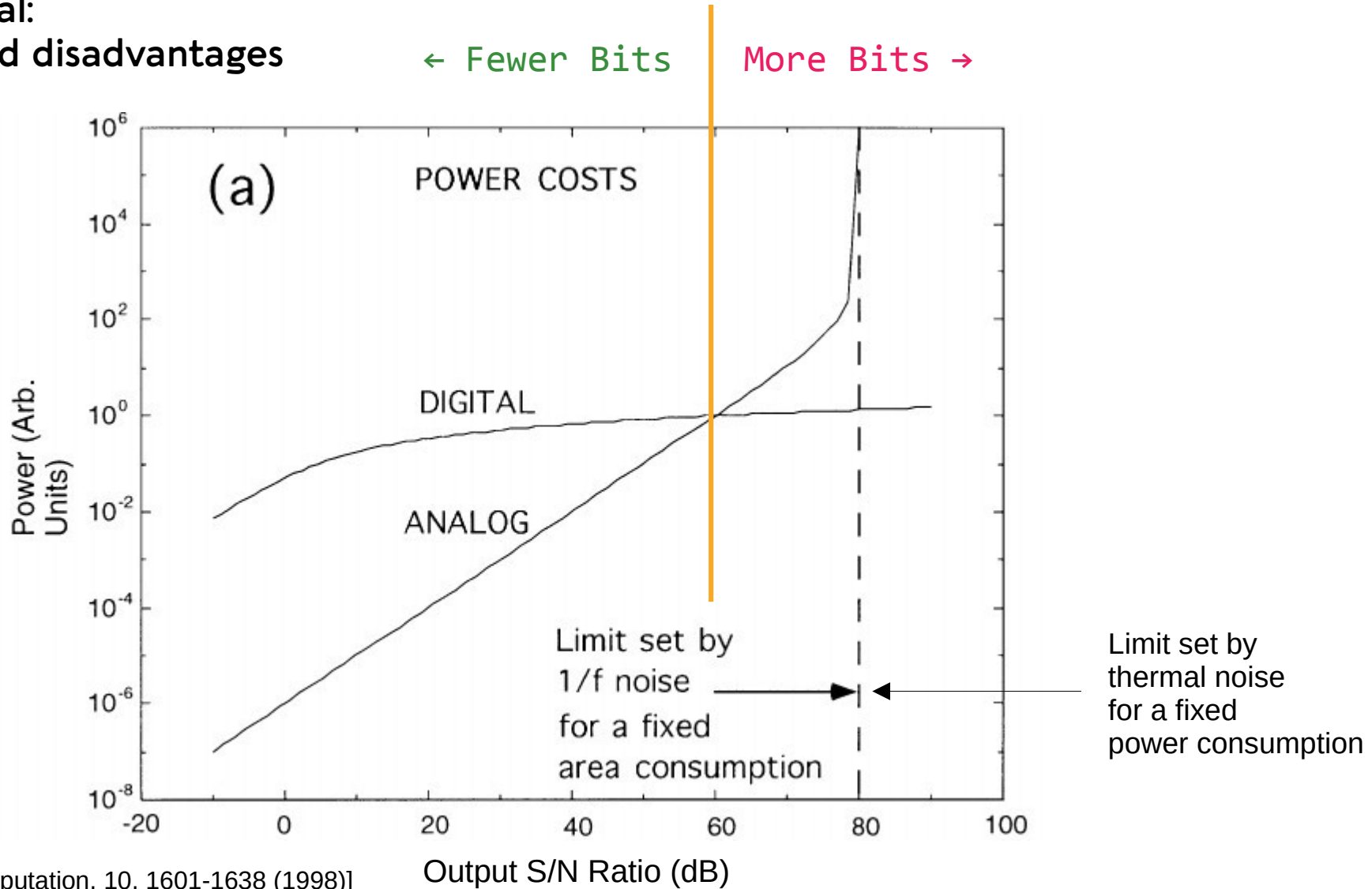

analog

vs

analogue

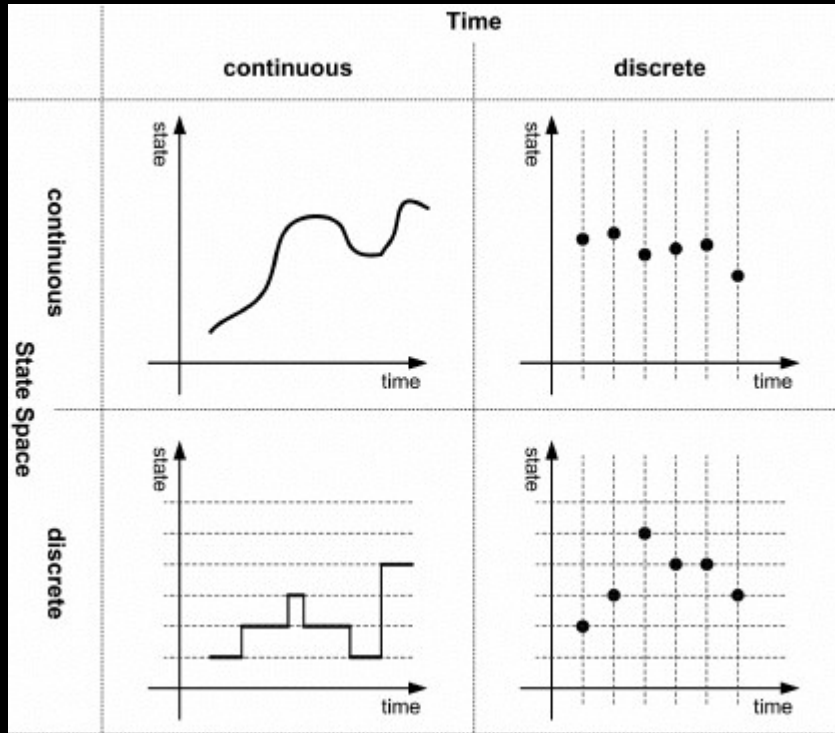

[10.14279/tuj.eceasst.27.385]

For reviews and surveys see for instance Bournez, Pouly 2018 [arxiv:1805.05729]

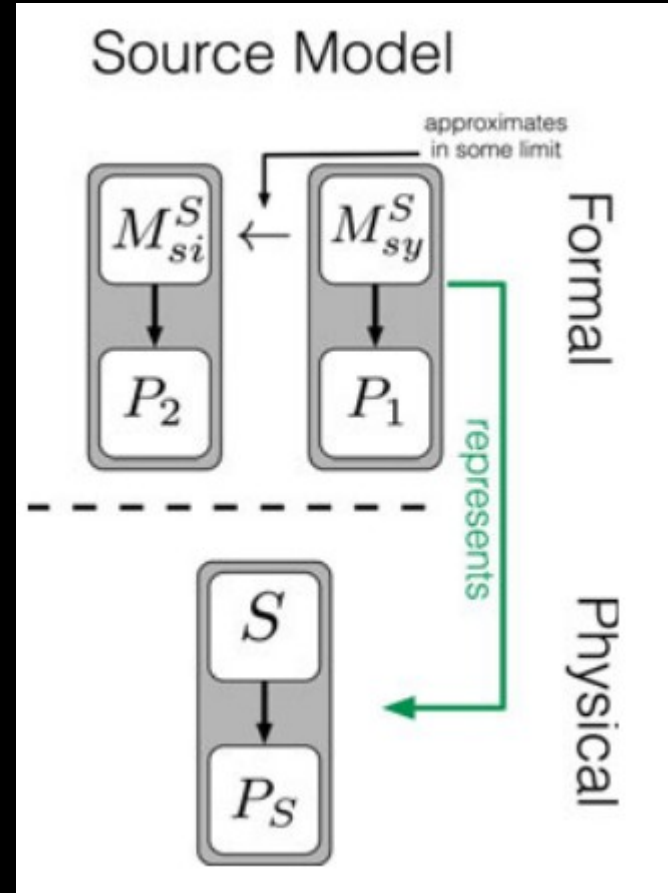

Direct & Indirect Analogies

[Hangleiter, Carolan, Thébault: Analogue Quantum Simulation, p.18]

The General Purpose Analog Computer by Claude Shannon [1941]

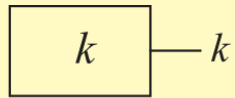

A constant unit associated to

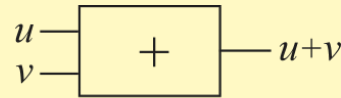

An adder unit

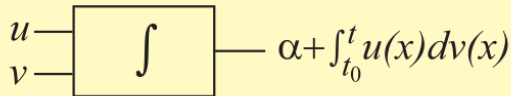

An integrator unit

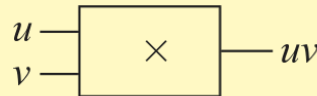

A multiplier unit

Spawns class of polynomial initial value problems (PIVP). PIVPs are polynomially equivalent to Turing Machines [Bournez, Pouly 2016].

Analog limitations: Fight or Embrace

- **Uncertainty:** 3-4 decimal numbers (8-10bit)
- Only one degree of freedom „time“ – otherwise hardware scales with problem size.
- **Scaling / BIBO: Number representation**

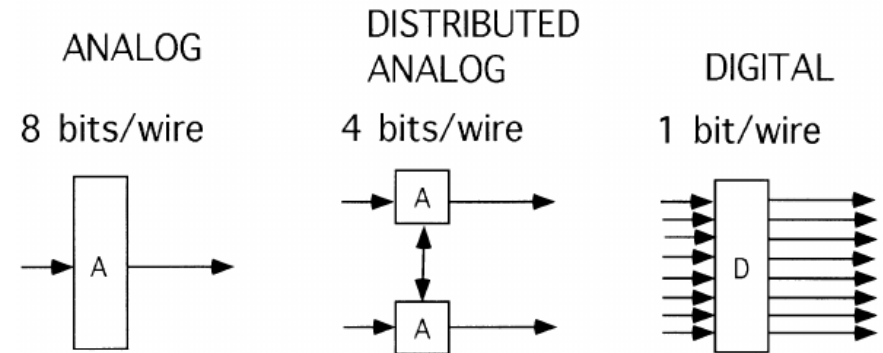

[Sarpeshkar, Neural Computation, 10, 1601-1638 (1998)]

Recent work: Applications in physics

Solving Partial Differential Equations like Euler Equations on Analog Computers

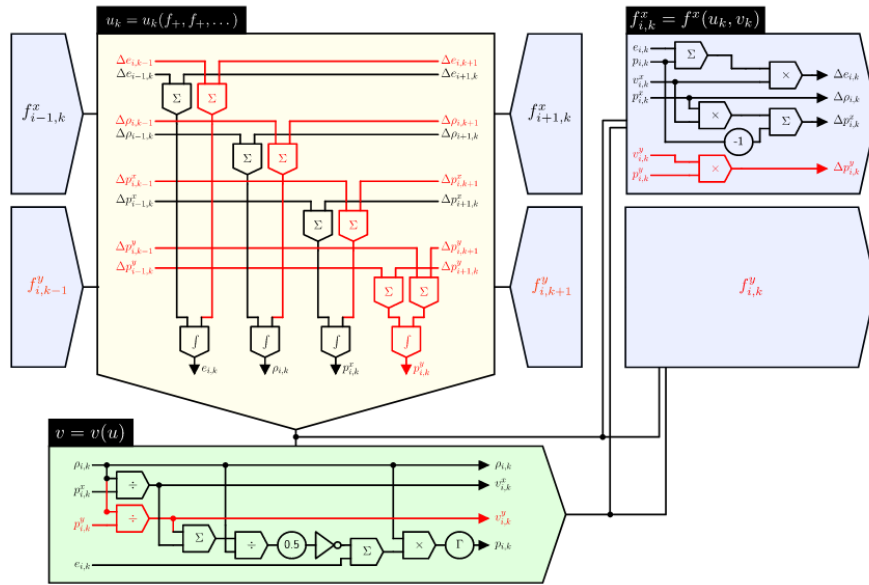

Köppel, Ulmann, Heimann, Killat: <https://arxiv.org/abs/2102.07268>
Advances in Radio Science 2020

N-body problems on analog computers (Molecular Dynamics water model motivational example)

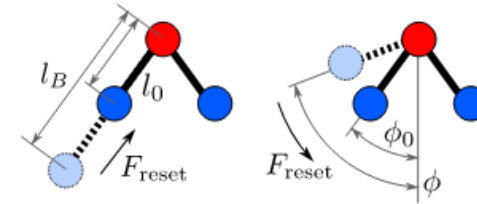

Fig. 1. Intramolecular degrees of freedom in the water molecule modeled as harmonic displacements: Bond stretching (Eq. 2) and angle bending (Eq. 3) between an oxygen atom (red) and an associated hydrogen atom (blue).

Köppel, Krause, Ulmann: <https://arxiv.org/abs/2107.06283>
Int. Journal of Unconventional Computing, Vol 17, No 4, 2022

Power and Time to Solution Measurements and Projections for the GPAC



Discrete
Analog
Computer

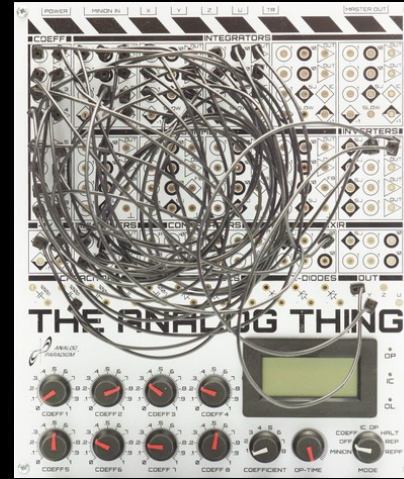

Integrated
Analog
Computer on
Chip

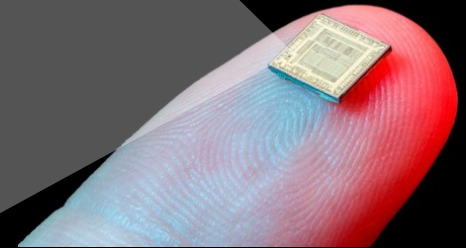

Integrated Digital benchmark

		Measured		Projected
		Digital	Analog (<i>MI</i>)	Analog Chip
Time to Solution:	T [μs]	75 ± 45	100	$10^{-(0.5 \pm 0.5)}$
Cutoff frequency (bandwidth):	$k_0 \sim 1/\Delta t$ [Hz]	3×10^4	10^4	$10^{6.5 \pm 0.5}$
Power consumption:	P [W]	10	0.4	10^{-2}
Energy for computation:	$E = P \cdot T$ [μJ]	900 ± 600	40	$10^{-(2.5 \pm 0.5)}$
(effective) FLOPs:	F [FLOP/sec]	10^9	$3 \times 10^{(4 \pm 1)}$	7×10^5
Efficiency (FLOPs per Energy):	F/E [FLOP/J]	10^8	$7.5 \times 10^{8 \pm 1}$	3×10^{11}

The Analog Thing



- Affordable tabletop computer for science and education.
- Open source hardware invites for tinkering and modifying.
- Simple interfaces to [Arduino](#), [Raspberry Pi](#), etc.
- Getting started [without laboratory equipment](#) (sound card as oscilloscope)

$$\begin{aligned}
 -x &= -\int 1.8y - x \, dt + C \\
 -z &= -\int 1.5xy - 0.2667z \, dt \\
 s &= -(1 - 2.68z) \\
 r &= -xs \\
 -y &= -\int 1.536r - 0.1y \, dt
 \end{aligned}$$

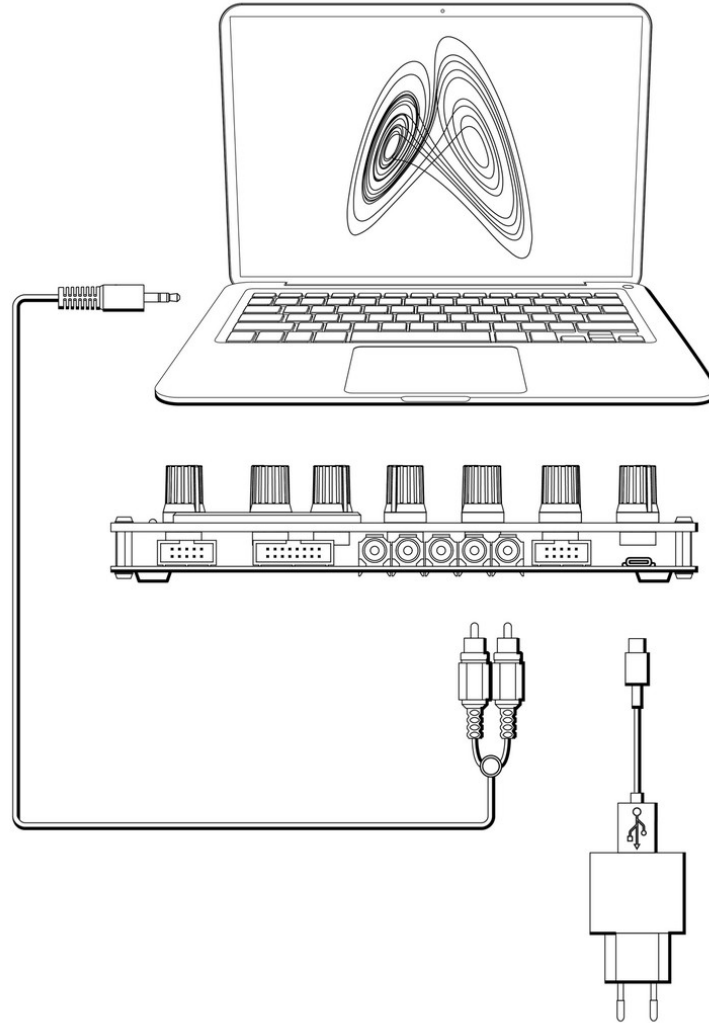
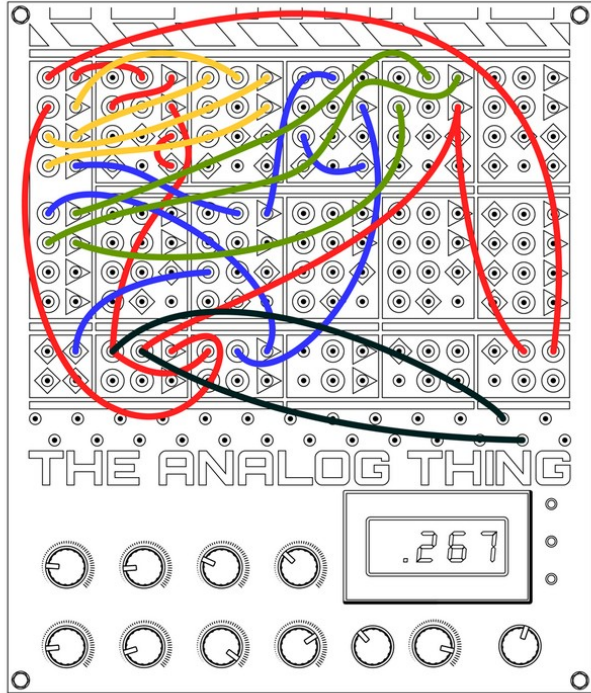
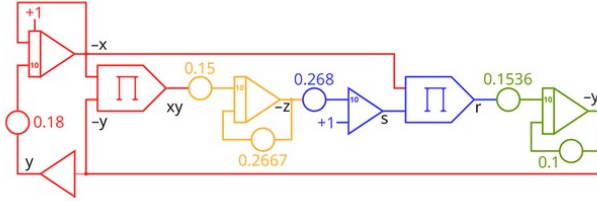

Recent work in hardware: First fully-reconfigurable discrete analog computer, to be released in a few weeks

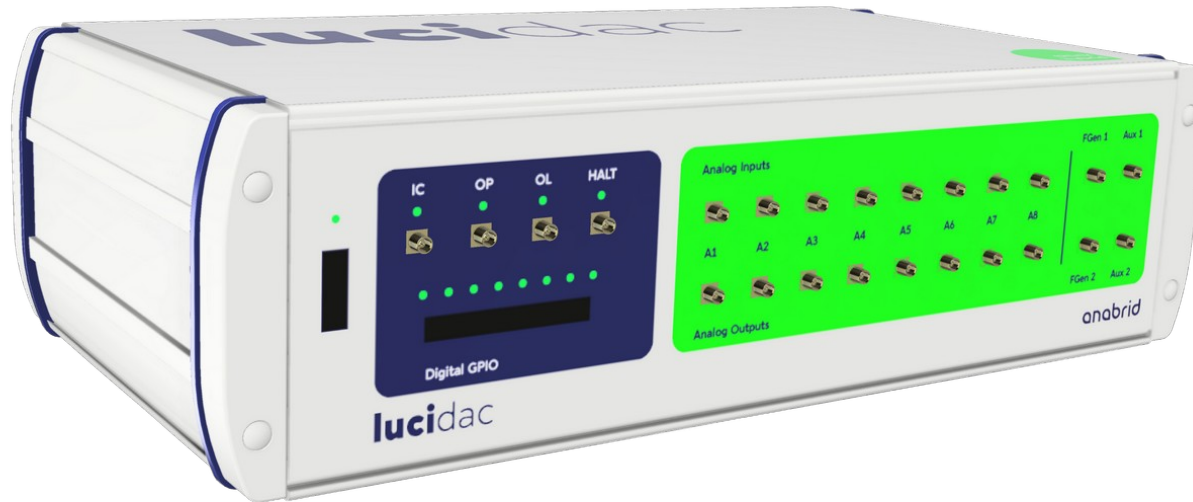

Recent work in hardware: First fully-reconfigurable discrete analog computer, to be released in a few weeks

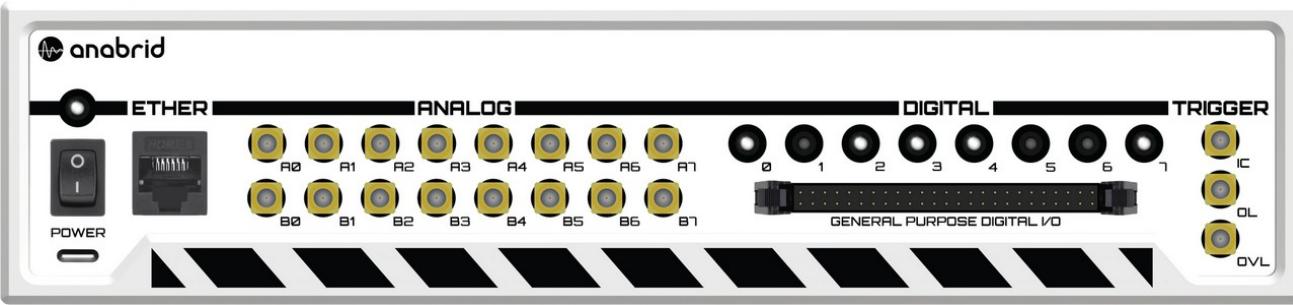
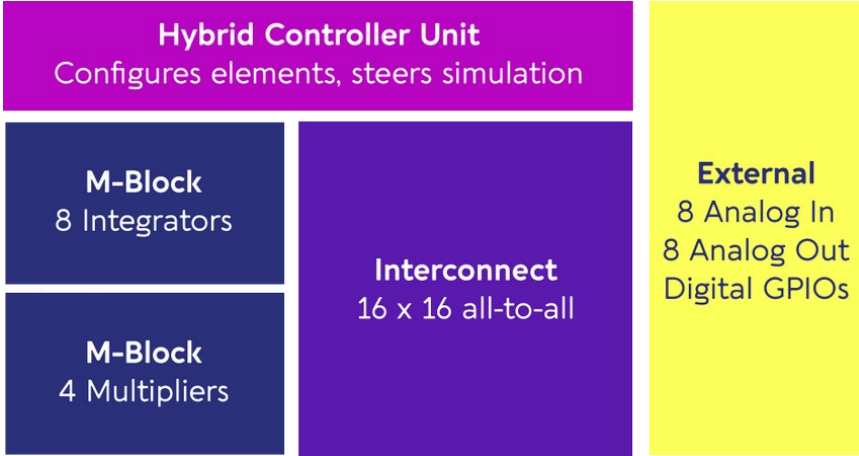
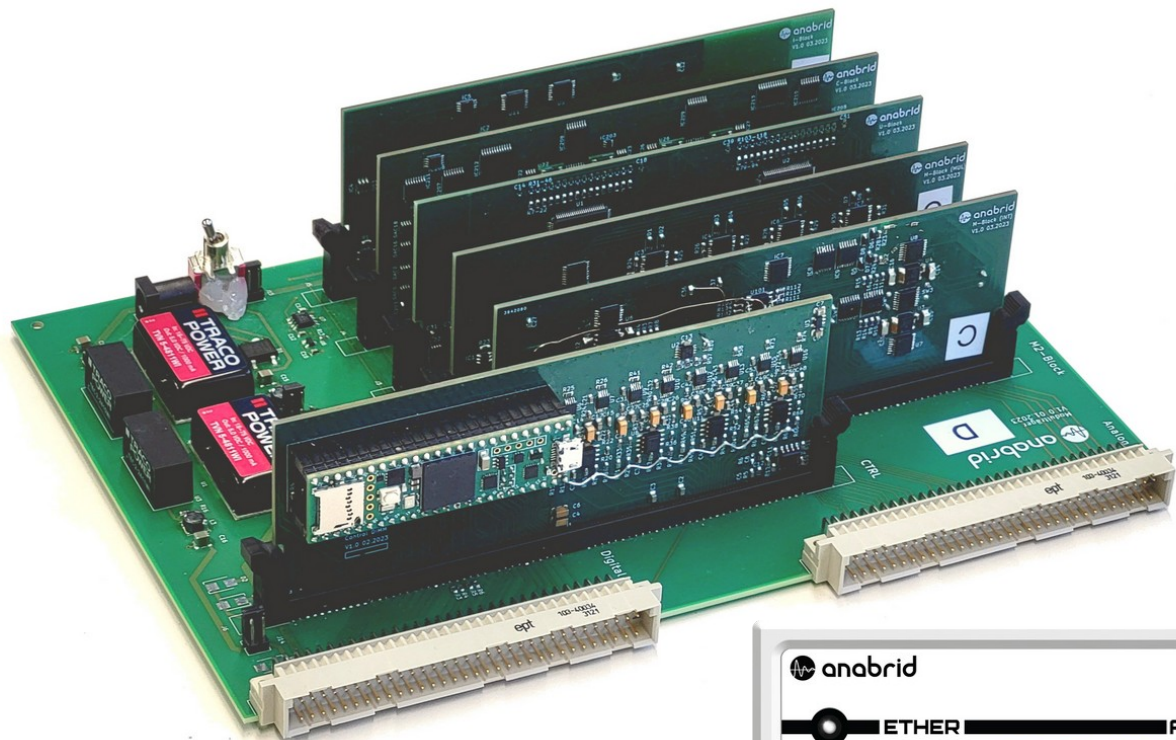

Precision
Up to 12bit resolution.
DC accuracy 0.1%
AC bandwidth > 1Mhz (cutoff frequency).

OIM as a direct analogy to force networks, on analog computers

Opamp-based amplified-damped oscillator model

$$\frac{d}{dt} \begin{pmatrix} y_i \\ z_i \end{pmatrix} = \begin{pmatrix} A & 1 \\ -\omega_0^2 & -D \end{pmatrix} \begin{pmatrix} y_i \\ z_i \end{pmatrix} + \begin{pmatrix} AF_i \\ F_i \end{pmatrix}$$

with $\delta=D$ and $\alpha=\omega_0^2A$

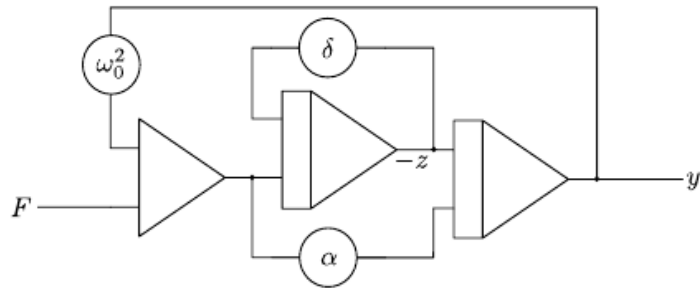

4-spin all2all system with 16 DPTs and SHIL

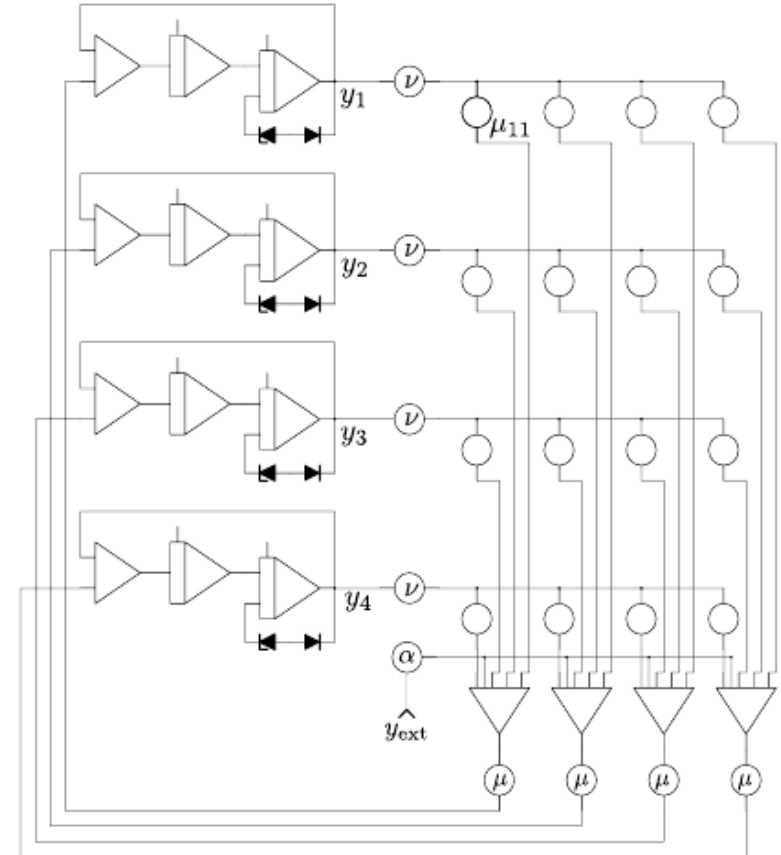

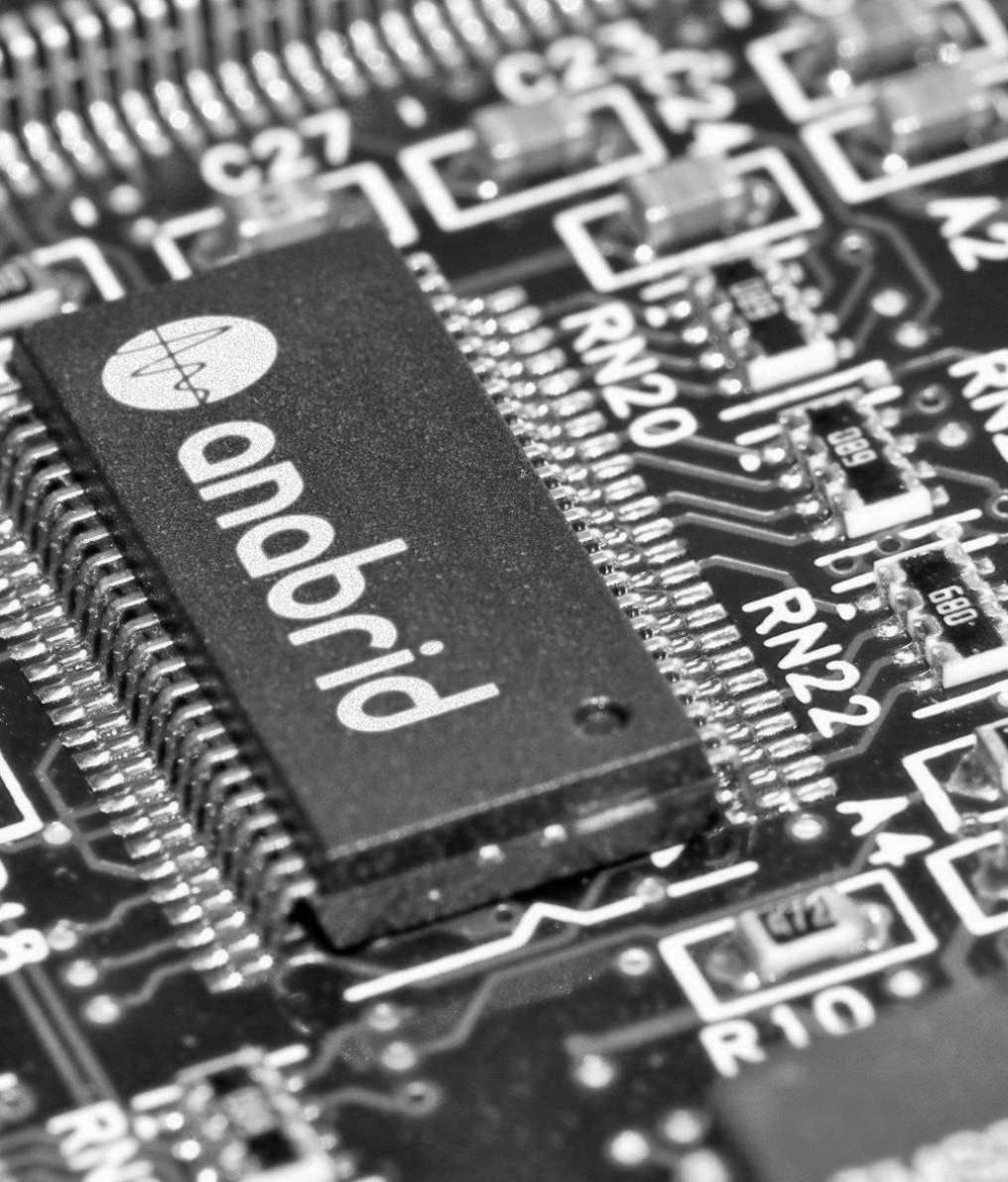

Simple Ising machines for educational and research purposes

Dr. Sven Köppel
koepfel@anabrid.com

Shrish Roy
roy@anabrid.com

2024-04-18
International Workshop on Ising Machines
2024, Messina, Italy

Lucas yesterday 15 minutes on: Delay in self-synchronized networks & 2nd order Kuramoto model.

Sven 15 minutes on: The Analog Paradigm of computation, open hardware for education.

Shrish 15 minutes on: Early results on a small Ising machine we built on this platform.

Simple Ising machines for educational and research purposes

Dr. Sven Köppel
koeppe@anabrid.com

Shrish Roy
roy@anabrid.com

2024-04-18
International Workshop on Ising Machines
2024, Messina, Italy

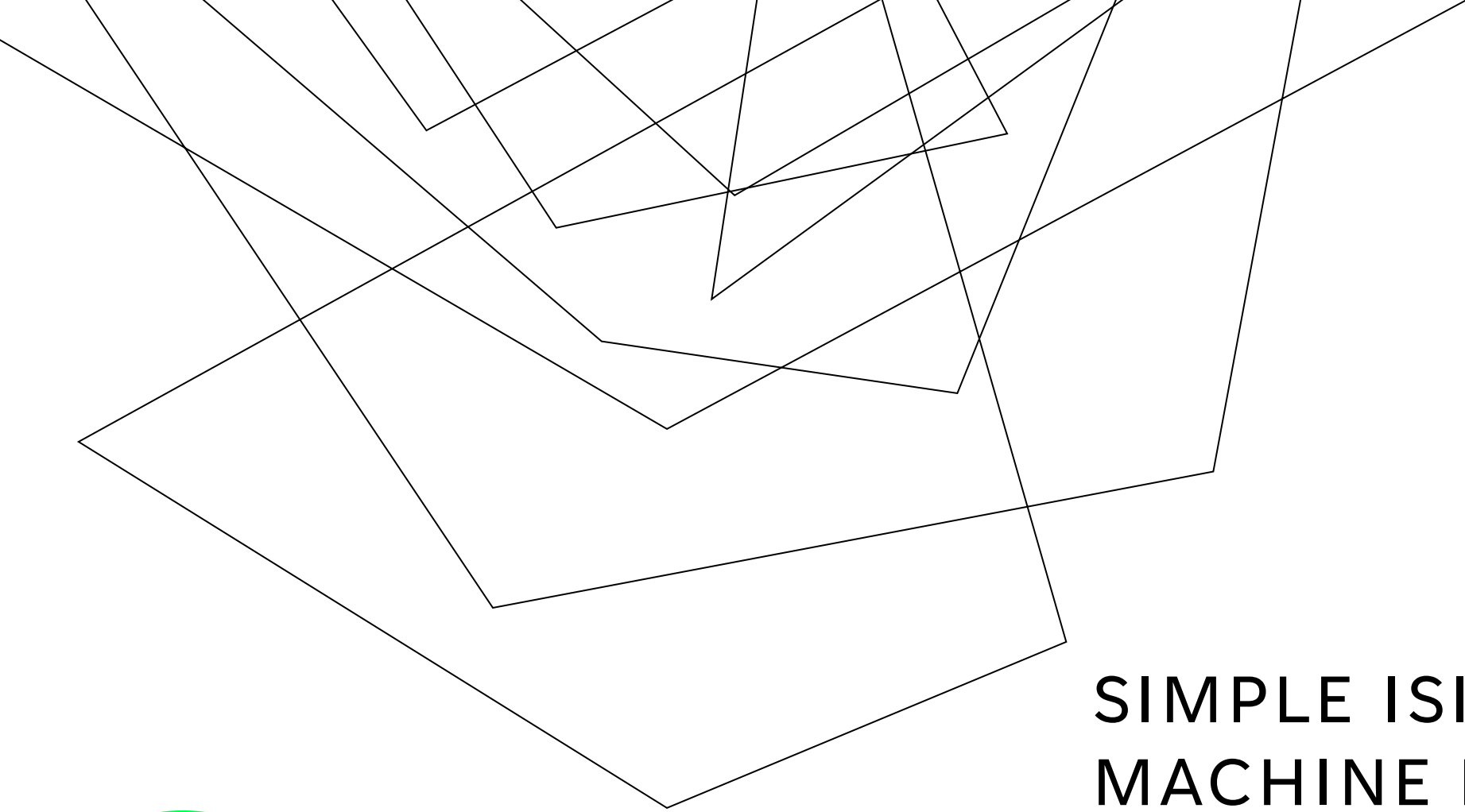

**SIMPLE USING
MACHINE FOR
EDUCATIONAL AND
RESEARCH PURPOSES**



WHAT IS THIS HALF OF THE TALK GOING TO BE ABOUT?

1. Our implementation of an Oscillator based ising machine.
2. Tests that we performed on it.
3. Discussing conclusions of the results.
4. Further things we would like to explore.

INTRODUCTION

- In 2021 Bernd Ulmann and Sven Köppel started to play around with the idea of building an Oscillator based Ising machine.
- The first inspiration for it came from the 2017 paper on...

Oscillator-based Ising Machine

Tianshi Wang and Jaijeet Roychowdhury

Department of Electrical Engineering and Computer Sciences, University of California, Berkeley, CA, USA

Email: {tianshi, jr}@berkeley.edu

INTRODUCTION

- Fast forward to Christmas of 2023... Bernd builds the first 4 phase shift oscillators, with all to all couplings available, on a single prototype board (left) and the complete working setup (right)...

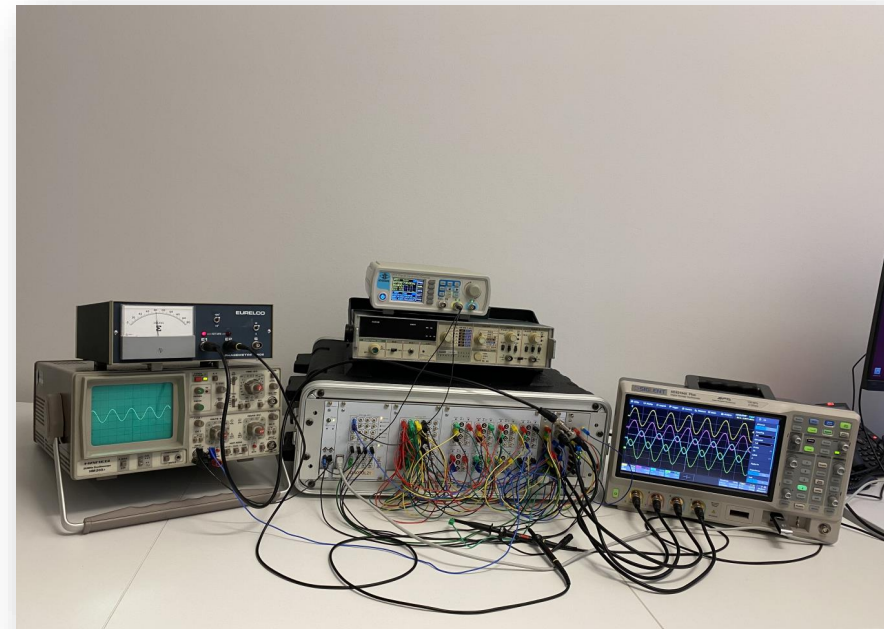
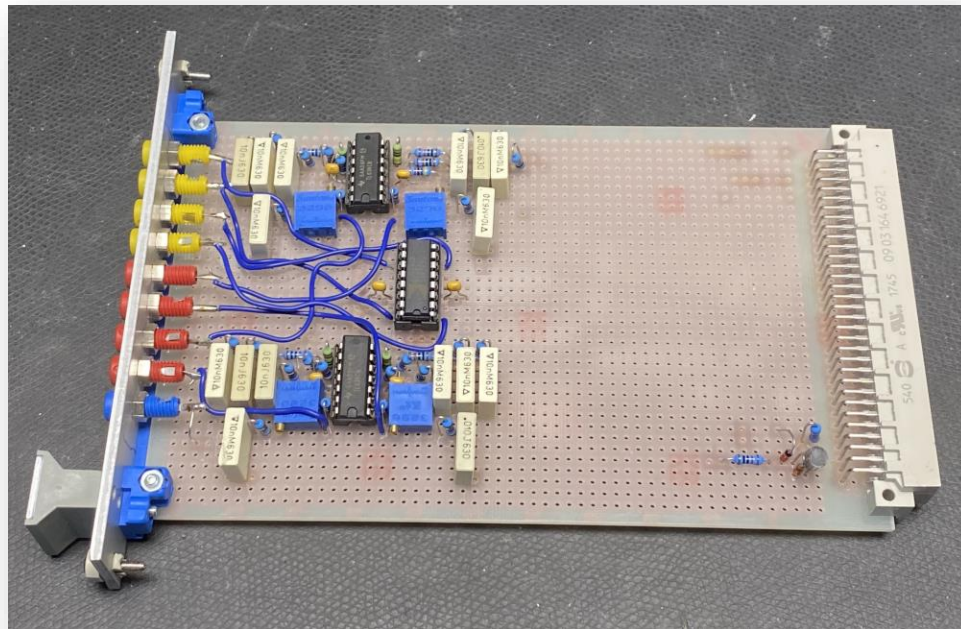

DETAILS OF THE FIRST LAYOUT

- The four yellow jacks are the synchronisation inputs.
- The four red jacks are the oscillator output signals.
- The blue jack at the bottom of the card is fed with a control signal that connects or disconnects all synchronisation inputs at once to/from the oscillators. (This is necessary as setting the coupling coefficients is a sequential process which might yield to undesired synchronisation between oscillators during setup.)

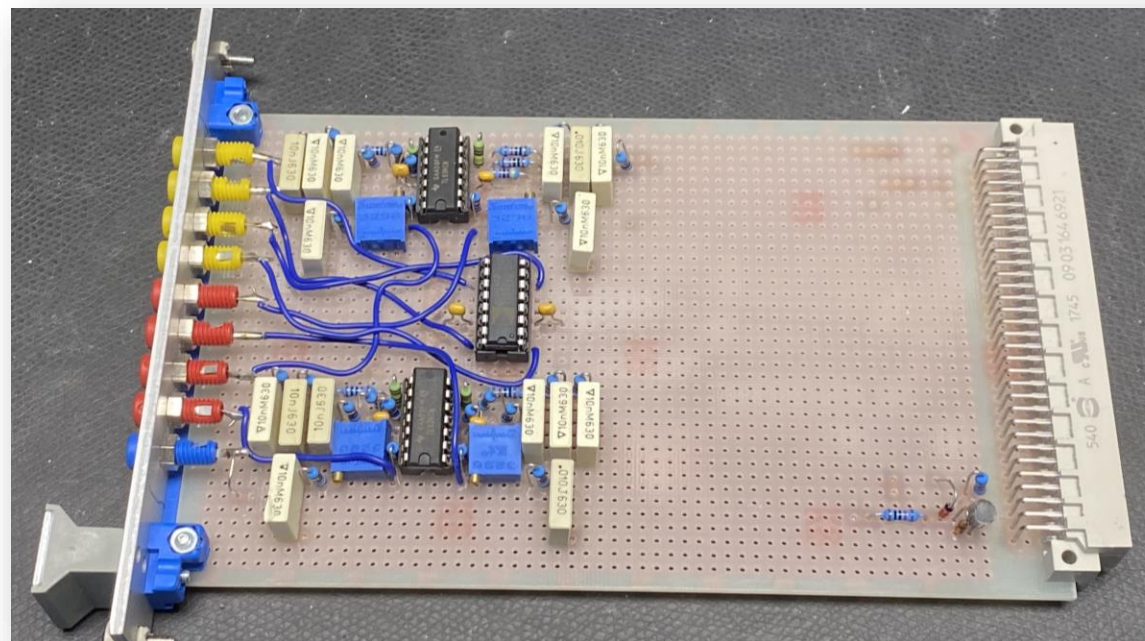

DETAILS OF THE FIRST LAYOUT

Here we have our 4 oscillator
Ising machine with additional
equipment such as:

1. Phase meter (top left)
2. Another phase meter (centre)
3. SHIL (**S**econd **H**armonic
Injection **L**ocking) generator
(top middle)
4. Four channel oscilloscope
(right)
5. Our 4 oscillator OIM (bottom
center)
6. Oscilloscope (right)

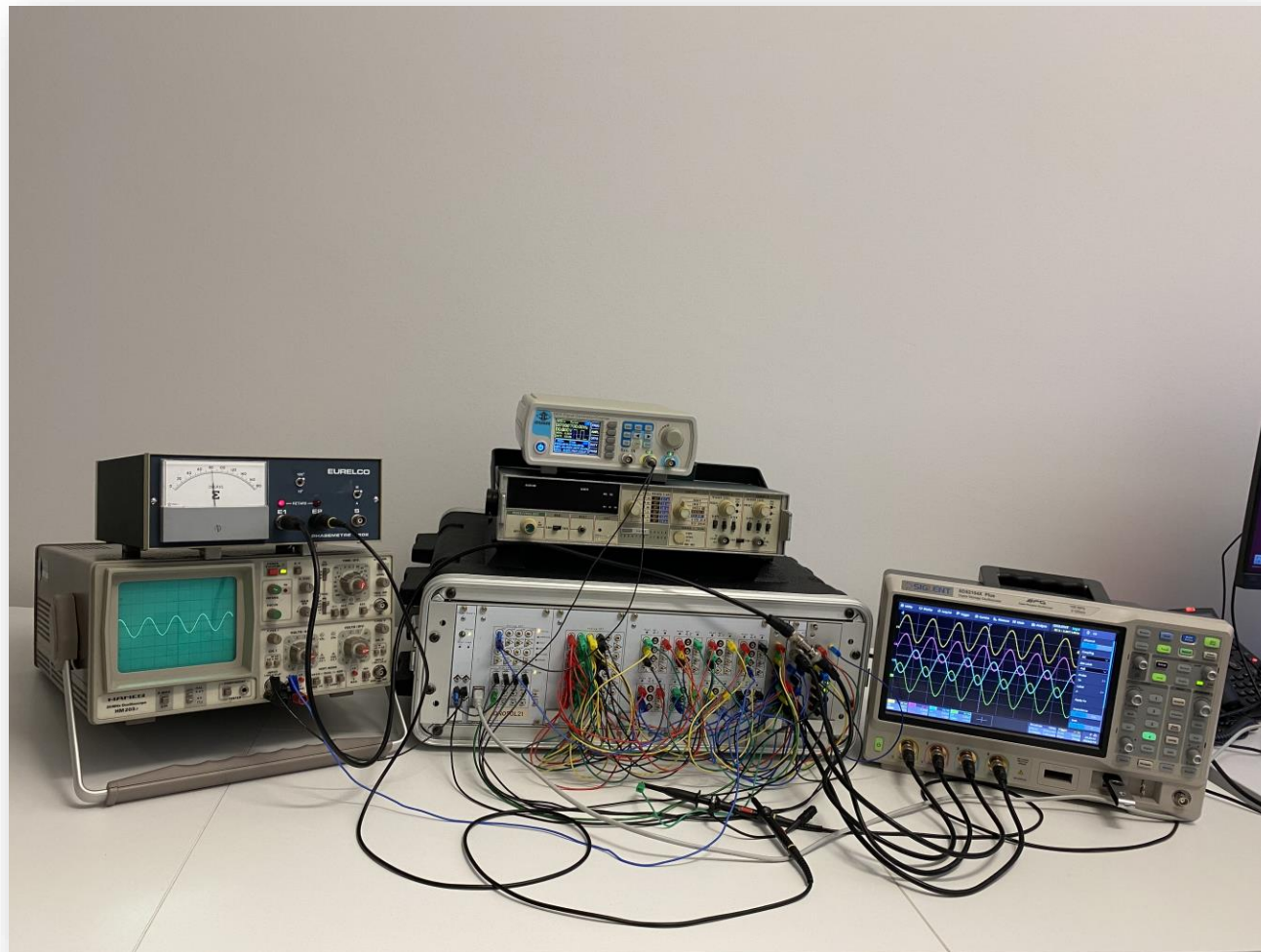

INITIAL TESTING

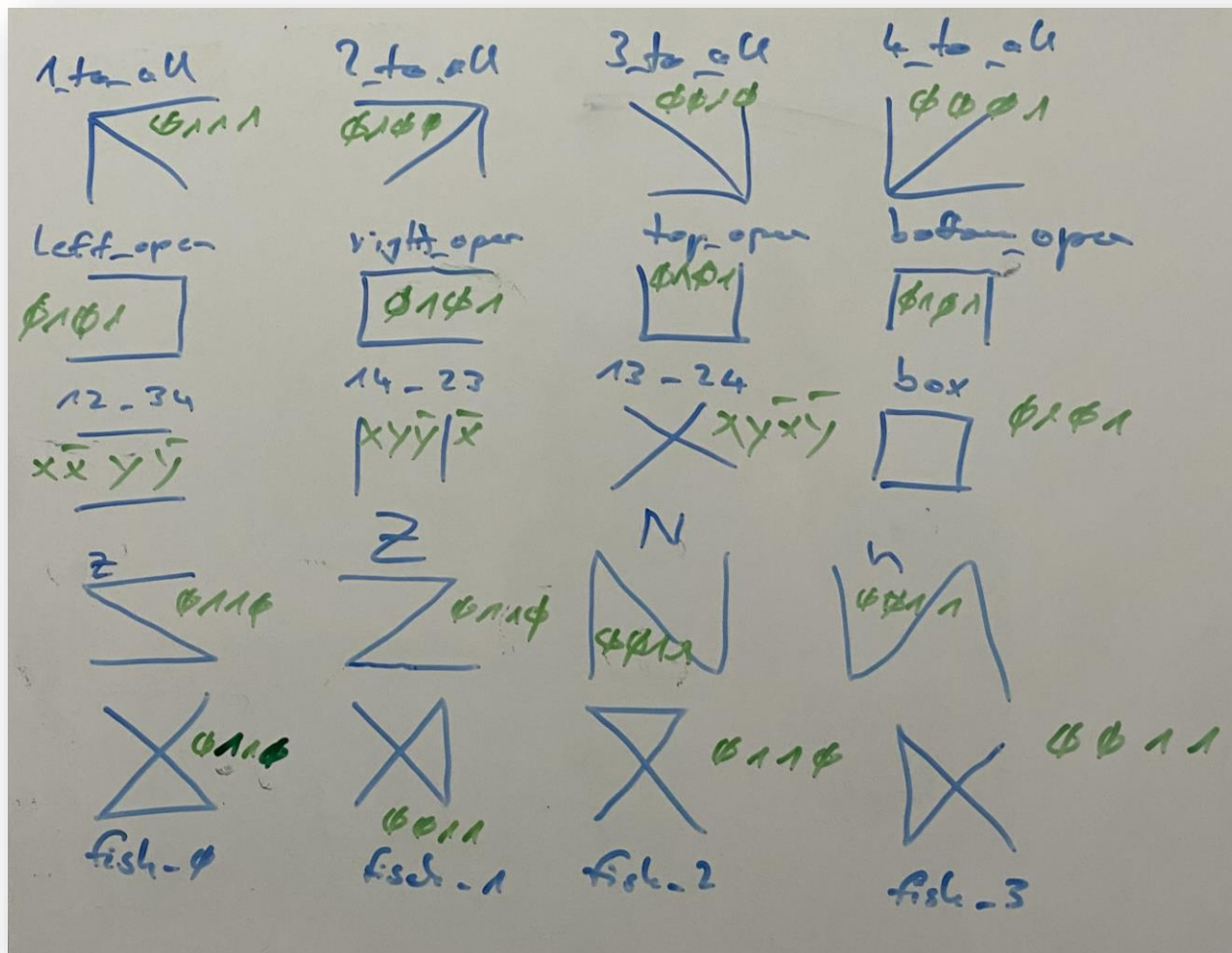

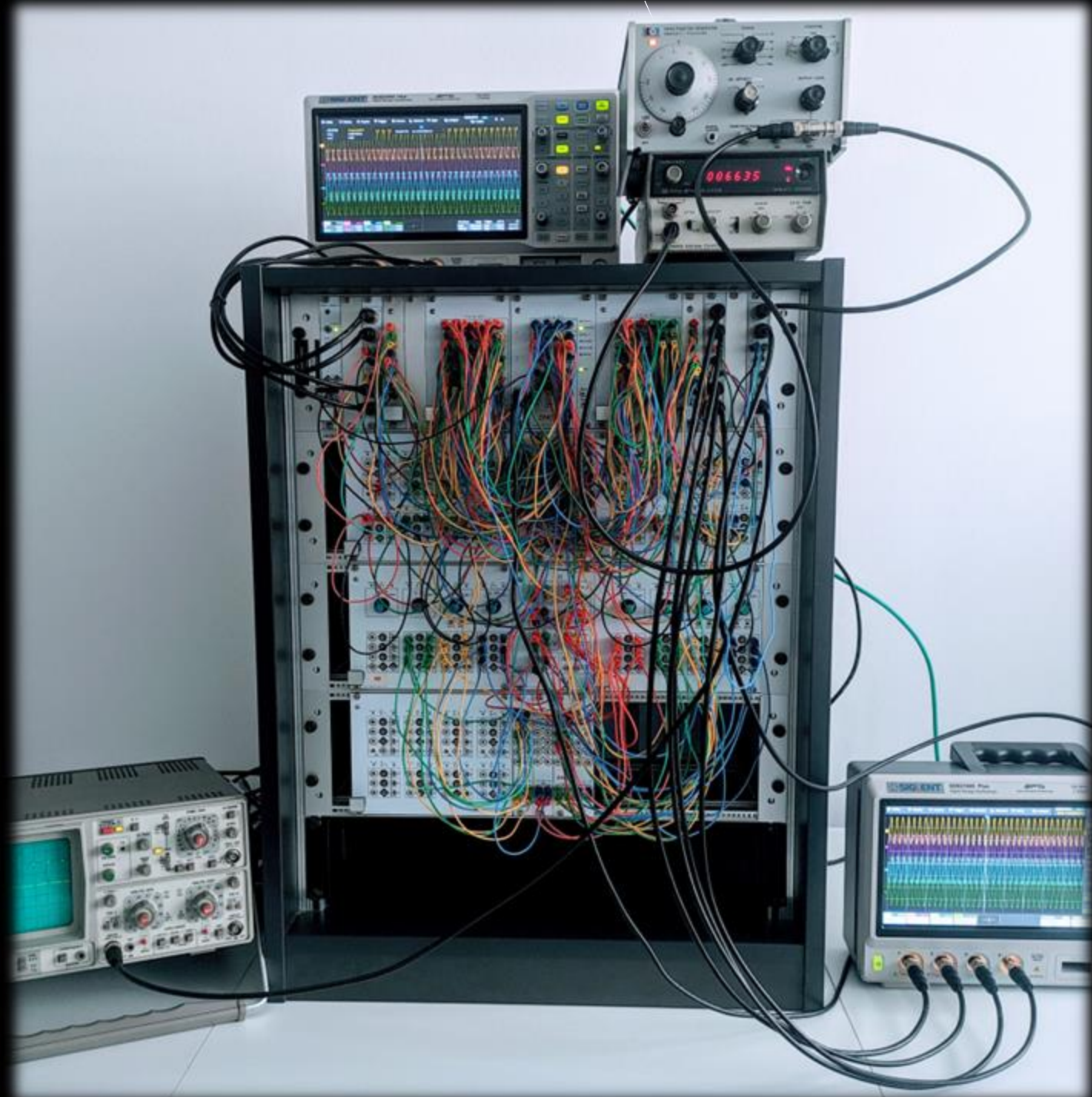

CURRENT IMPLEMENTATION

SCHEMATICS

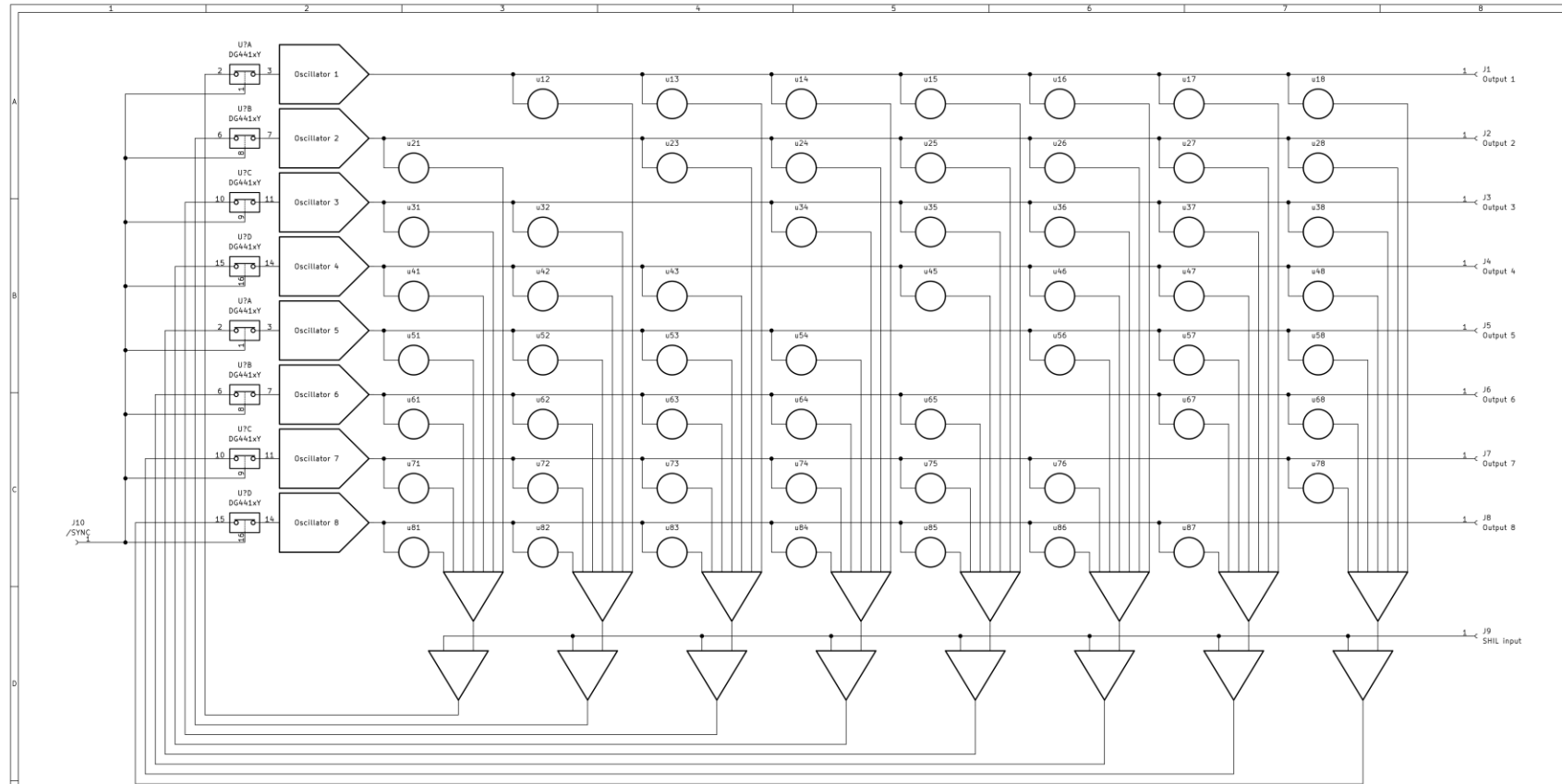

Each coefficient element (u_{ij}) looks like this
(with supply and control lines connected accordingly):

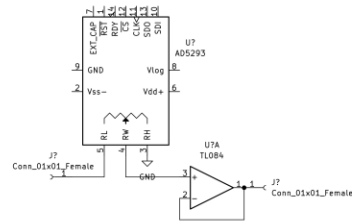

Bernd Ulmann		
anabrid GmbH		
Sheet: 7		
File: IsingB.kicad_sch		
Title: Eight oscillator Ising machine		
Size: A3	Date: 06.03.2024	Rev: 1
KiCad E.D.A. eeschema (6.0.7-1)-1		Id: 1/1

TESTS ON THE 8 OSCILLATOR ISING MACHINE

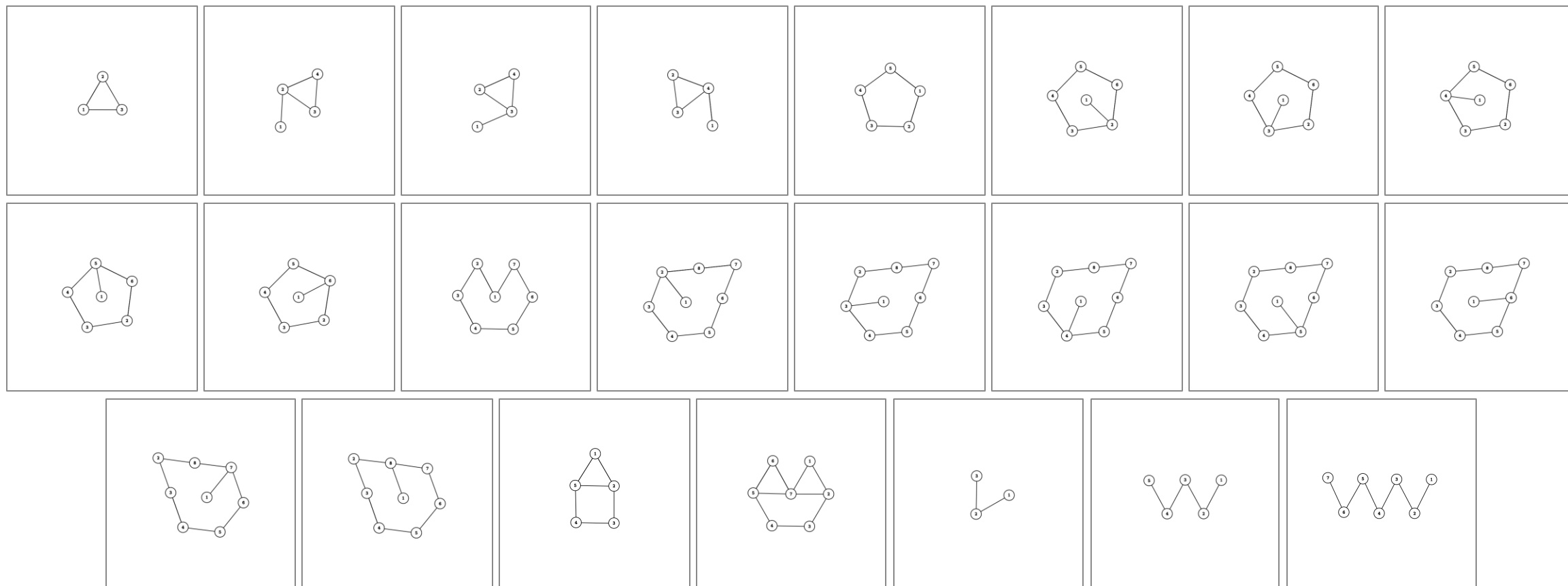

And more...



WHY THESE SPECIFIC GRAPHS?

- These are graphs for max cut problems that we can compute the solutions for and check if our machines produces the right solution.
- To check if different assignment of oscillators for the same graph is producing the same solution or not?
- Easier to visualize ,map onto hardware and test!

WHAT IS A MAX-CUT PROBLEM?

Given an undirected graph $G=(V,E)$. A max cut problem outputs a partition of vertices into two subsets V_1, V_2 such that the number of edges between V_1 and V_2 is maximized.

A GUIDE TO WHAT THE SOLUTION LOOKS LIKE...

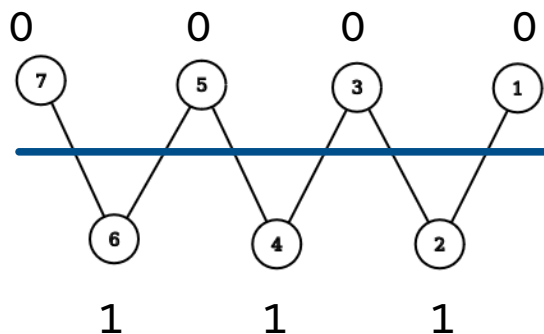

Here we interpret the solution as follows:

0101010

In our system, oscillator 1 is a reference oscillator (it will always be 0) meaning we'll be measuring if the other oscillators are in or out of phase in reference to oscillator "1".

OSCILLATOR EIGENFREQUENCIES

Oscillator number	1	2	3	4	5	6	7	8
Frequency	3269Hz	3457Hz	3341Hz	3333Hz	3443Hz	3292Hz	3371Hz	3551Hz

Frequencies of the SHIL chosen for the test: 6400 Hz, 6800 Hz, 7200 Hz

Each problem was repeated 100 times to generate statistics with different intensities of SHIL (0 V, 0.5 V, 2.5 V)

SOLUTION INTERPRETATION FOR A HOUSE GRAPH $\{G(5,6)\}$

- House graph or $G(5,6)$ is a graph with 5 vertices and 6 edges.
- The solution 01010 indicates that the partitions are $(1,3,5)(2,4)$.
- The solution 00101 indicates that the partitions are $(1,2,4)(3,5)$.

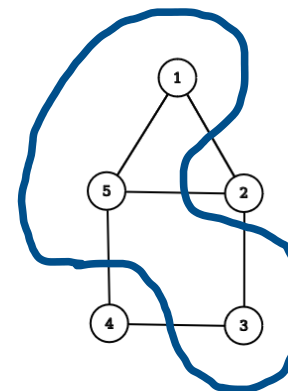

01010

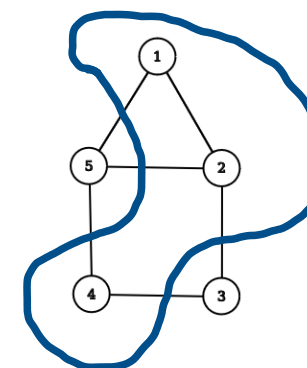

00101

OBSERVATIONS FROM THE RESULTS

Goodnews! The machine solves certain Max cut problems (well under certain conditions)

Name	Coupling strength	SHIL	Correct Solution(s)	Remarks, possible solutions and final results
Maxcut for G(5,6)	0.1	2.5V (6.4 KHz)	01010, 00101	Correct solution never appears
	0.2		01010, 00101	Correct solution appears 100% of the time. 00101 (18%), 01010 (82%)
	0.3		01010, 00101	Meaningless solutions, oscillators were not locking
	0.1	2.5V (6.8 KHz)	01010, 00101	Correct solution appears 99% of the time. 00101 (49%), 01010 (50%)
	0.2		01010, 00101	Correct solution appears 100% of the time. 00101 (31%), 01010 (69%)
	0.3		01010, 00101	Correct solution appears 100% of the time. 00101 (18%), 01010 (82%)
	0.1	2.5V (7.2 KHz)	01010, 00101	Correct solution appears 100% of the time. 01010 (100%)
	0.2		01010, 00101	Correct solution appears 100% of the time. 01010 (100%)
	0.3		01010, 00101	Meaningless

OBSERVATIONS FROM THE RESULTS

Name	Coupling strength	SHIL	Correct Solution(s)	Remarks, possible solutions and final results
Maxcut for G(5,6)	0.1	None	01010, 00101	Correct solution appears 36 % of the time
	0.2		01010, 00101	Correct solution never appears
	0.3		01010, 00101	Correct solution never appears
	0.1	0.5V (6.4 KHz)	01010, 00101	Correct solution 01010 appears 2% of the time
	0.2		01010, 00101	Correct solution never appears
	0.3		01010, 00101	Correct solution never appears
	0.1	0.5V (6.8 KHz)	01010, 00101	Correct solution never appears
	0.2		01010, 00101	Correct solution never appears
	0.3		01010, 00101	Correct solution never appears
	0.1	0.5V (7.2 KHz)	01010, 00101	Correct solution never appears
	0.2		01010, 00101	Correct solution never appears
	0.3		01010, 00101	Correct solution never appears

OBSERVATIONS FROM THE RESULTS

- Different problems require different coupling strengths to achieve a higher probability of “correct” outputs. What are these possible factors?
 - Nodes/Oscillators with more connections.
 - Closed odd numbered loops (circuits that are triangles, pentagons, heptagons...)
 - Depth of a graph (Bernd’s hypothesis)
- (Parasitic coupling) Because of the wiring there is some inherent coupling present in the system. An example of which can be seen here (0.5 V SHIL):

Name	Coupling strength	Solution Statistics
3-link	0.1	{010}10000: (94 %), {010}10010: (6 %)

Here oscillator 4 locks along with the other oscillators even if it is not coupled with the other oscillators. Won’t be a problem with the next generation.

OBSERVATIONS FROM THE RESULTS

- The probability distribution of the correct solutions changes if the connections change. For instance, let us look at two problems that are isomorphic to each other (2.5 V of SHIL):

Name	Coupling strength	Solution Statistics	Correct Solution	Remarks, possible solutions and final results
7-5-3-1-2-4-6-8	0.1	00110011: (1 %), 01100110:(50 %), 01110011: (49 %)	01100110	Correct solution appears 50% of the time
	0.2	01100011: (5 %), 01100110: (95 %)	01100110	Correct solution appears 95% of the time
	0.3	01100011: (1 %), 01100110: (99 %)	01100110	Correct solution appears 99% of the time
8-5-4-1-2-3-6-7	0.1	00110011: (6%), 00110101: (1%), 01001010: (4%), 01001100: (8%), 01010010: (3%), 01010011: (16%), 01010100: (5%), 01010101: (19%), 01011010: (8%), 01011100: (19%), 01101010: (2%), 01110010: (4%), 01110011: (2%), 01111010: (3%)	01010101	Correct solution appears 19% of the time
	0.2	01001010: (1%), 01001100: (1%), 01010011: (32%), 01010101: (27%), 01011100: (39%)	01010101	Correct solution appears 27% of the time
	0.3	01010011: (47%), 01010101: (53%)	01010101	Correct solution appears 53% of the time

OBSERVATIONS FROM THE RESULTS

- A coupling strength of ≥ 0.35 makes things act weird.
- In a configuration such as the one on the right. The oscillators seem to getting saturated. So, measurements can only be made at lower coupling strengths.

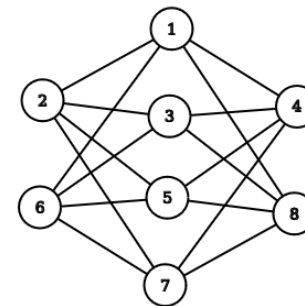

THINGS TO EXPLORE

- What is the phase response curve of our oscillators?
- Phase dynamics of the system of coupled oscillators under the influence of SHIL.
- Explore new implementation with other types of oscillators (LC, PLLs)
- New hardware topologies that are most efficient, in terms of:
 - Connectivity
 - Mapping of problems onto the hardware
- What happens when we scale the system?
- Our goal is the create an Ising machine with 10^4 oscillators.

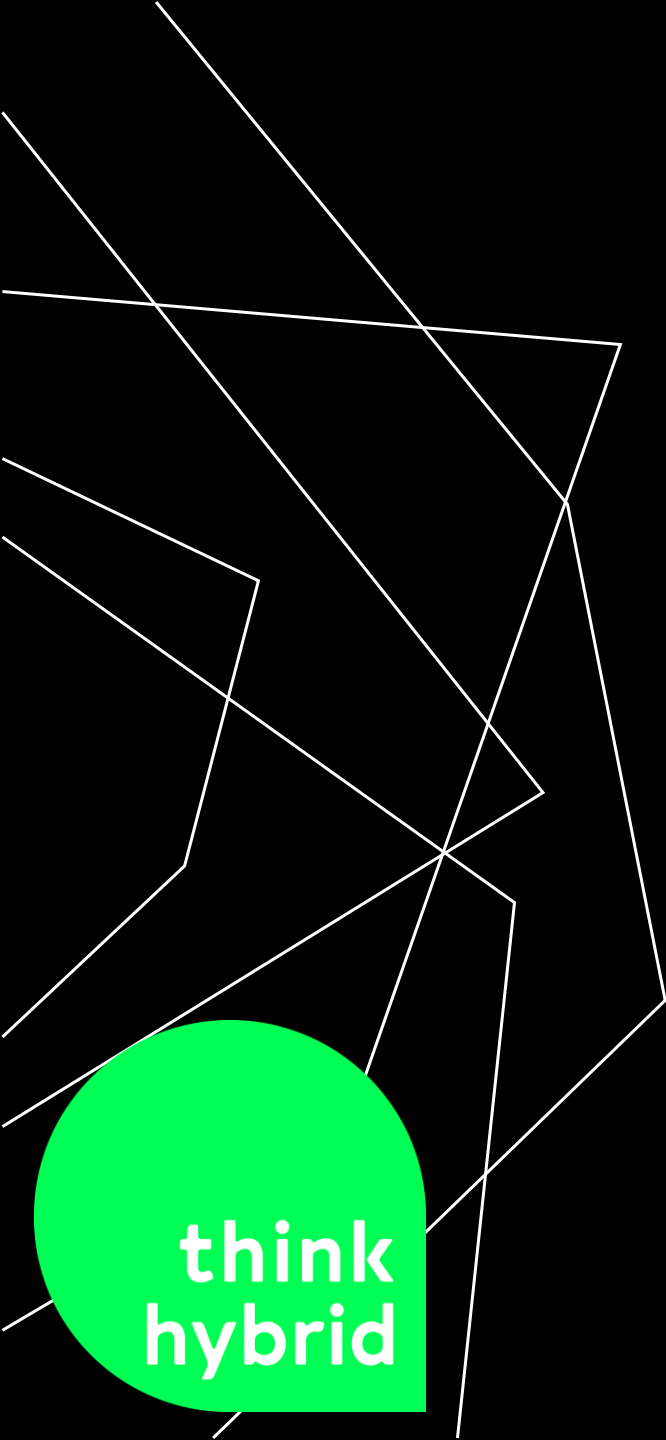

**think
hybrid**

THANK YOU